



IDC5
SOFTWARE
UPDATE

CAR 76.6.1



June 2024

IDC5 CAR 76.6.1

The **IDC5 CAR 76.6.1** software update includes, once again, a large number of developments, the best of TEXA's multi-brand diagnosis dedicated to cars and light commercial vehicles. Using **IDC5 CAR** during your daily workshop activities means having an avant-garde solution, rich in new diagnostic possibilities, special functions and technical information that are essential for completing even the most complex workshop operations professionally and with full customer satisfaction.

IDC5 CAR 76.6.1 includes the update of as many as **44 makes**. The work of TEXA's technical developers also led to further increasing the coverage of the **ADAS, electric and hybrid vehicles, interactive "DASHBOARD" screens** with over **190** new possible selections, and **wiring diagrams**.

IDC5 CAR 76.6.1 is characterised by over 6300 new possible selections for the major makes on the market worldwide, among which: **ABARTH, ACURA, ALFA ROMEO, ASTON MARTIN, AUDI, BENTLEY, BMW, BUICK, BYD, CADILLAC, CHERY, CHEVROLET, CHRYSLER, CITROËN, CUPRA, DACIA, DAIHATSU, DATSUN, DODGE, DR, DS, EVO, FERRARI, FIAT, FISHER, FORD, GENESIS, GMC, GREAT WALL, HOLDEN, HONDA, HUMMER, HYUNDAI, INEOS, INFINITI, ISUZU, JAGUAR, JEEP, KG MOBILITY, KIA, LADA, LANCIA, LAND ROVER, LAMBORGHINI, LDV, LEXUS, LINCOLN, LYNK & CO, MAXUS, MAYBACH, MASERATI, MAZDA, MCLAREN, MERCEDES-BENZ, MERCURY FORD, MG, MINI, MITSUBISHI, NISSAN, OPEL, PEUGEOT, POLESTAR, PONTIAC, PORSCHE, RAVON, RENAULT, RENAULT SAMSUNG, ROEWE, ROLLS-ROYCE, SAAB, SATURN, SCION, SEAT, SKODA, SPORTEQUIPE, SMART, SSANGYONG, SUBARU, SUZUKI, TATA, TESLA, TOYOTA, TROLLER, UAZ, VENUZIA, VOLKSWAGEN, VOLVO.**

To learn more about the extraordinary coverage made available by TEXA, visit the website:

www.texa.com/coverage

LATEST IDC5 CAR VERSION UPDATE

In the **"Latest version application list"** section users can find the updates related to the diagnostic coverage available in the **IDC5 CAR** software (Image 1).

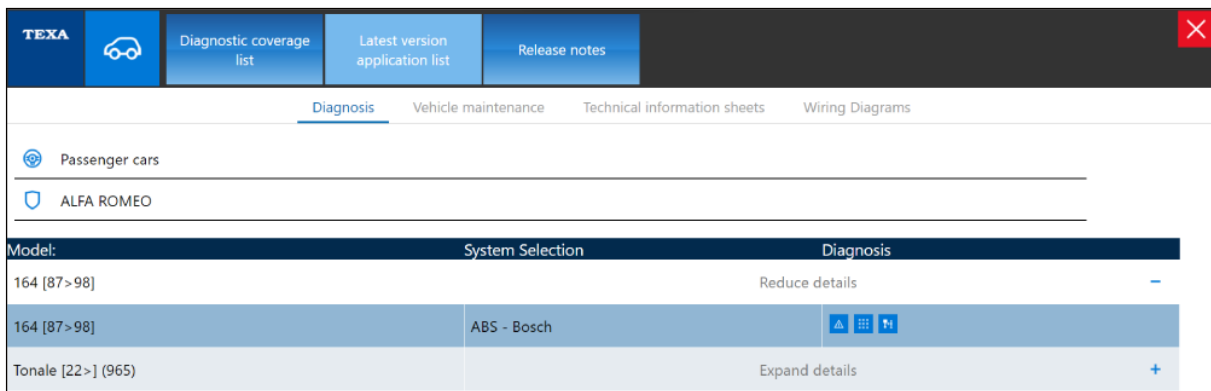

Image 1 - News section in IDC5

NOTE: For further information see our website WWW.TEXA.COM in the DIAGNOSTIC COVERAGE section.

NEW FEATURES INCLUDED IN THE IDC5 CAR 76.6.1 VERSION**COVERAGE EXTENDED ON MASERATI VEHICLES
WITH SECURE GATEWAY UNLOCK****NEW REMOTE DIAGNOSIS PORTAL****DIAGNOSTIC DASHBOARDS AND TGS3 DASHBOARDS****DIAGNOSIS****COVERAGE EXTENDED ON MASERATI VEHICLES
WITH SECURE GATEWAY UNLOCK**

With the **IDC5 CAR 76.6.1** version, the diagnostic coverage has been extended to **MASERATI** vehicles. Among these we want to point out the development of the diagnosis for the models **Grecale (M182)**, **GranTurismo (M189)** and **MC20 (M240)**.

ATTENTION! For the models indicated previously, if using the **Navigator TXTs** or **Navigator NANO S** diagnostic tool, the CAN-FD **S17350** (for Navigator TXTs) or CAN-FD **S17210** (for Navigator Nano S) adapter cable may have to be used.



**Navigator TXT CAN-FD
adapter S17350**



**Navigator NANO CAN-FD
adapter S17210.**

NOTE: For reasons that do not depend on TEXA, we wish to inform you that the calibration of the front camera on the models **Ghibli**, **Quattroruote** and **Levante** with Secure Gateway may fail, even if the latter is unlocked successfully. TEXA is working to solve this issue to guarantee the positive outcome of this operation.

We wish to be clear that the **MASERATI** in **IDC5** does not imply additional costs for subscribers. For any questions on the procedure for creating a **myTEXA** account or on the authentication in IDC5 see the available information material or ask for assistance from your distributor.

NEW REMOTE DIAGNOSIS PORTAL

With the **IDC5 CAR 76.6.1** version, TEXA has included a new portal for accessing the multi-brand diagnosis service, which allows repairers to complete operations that are not in the software updates or that may be complex. Thanks to this new, simple and intuitive portal, you can enter new requests other than always have visibility of the history of the requested operations.

This portal and the related Remote Diagnosis service can be accessed by all customers who have subscribed a **TEXPACK CAR** subscription and who have created and validated an account in myTEXA portal.

NOTE: Based on the country of origin the subscription may vary for some services.

The portal can be reached from the IDC5 CAR environment in the diagnosis page by clicking on "**Remote Diagnosis**".

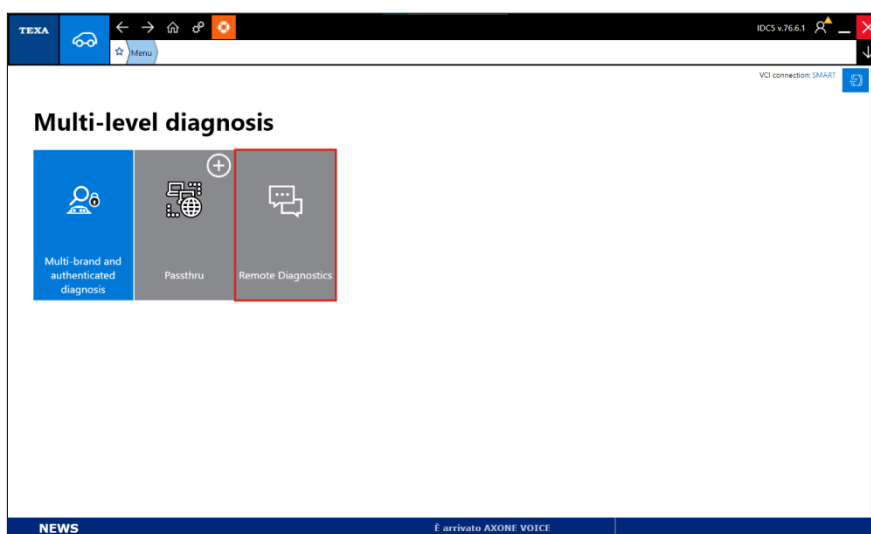

Furthermore, the portal can also be accessed in diagnosis from the menu on the left in the vehicle selection page clicking on **"Remote Diagnosis"**.

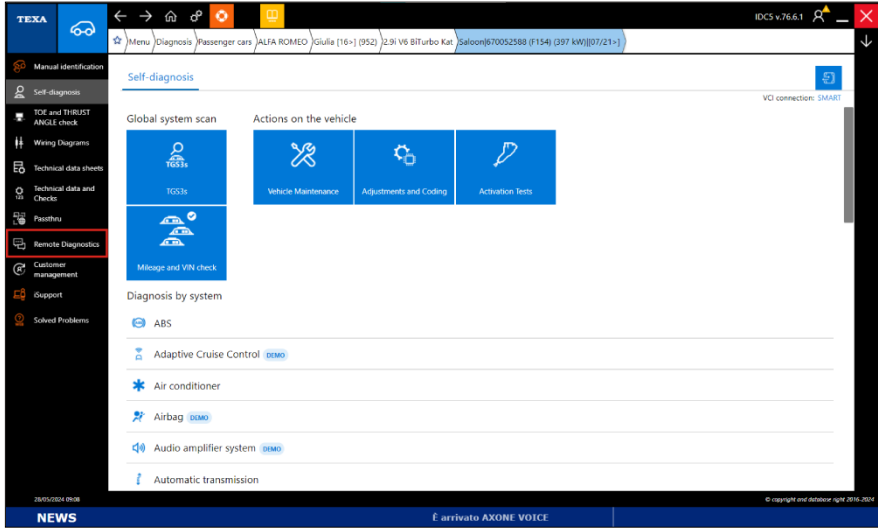

DIAGNOSTIC DASHBOARDS AND TGS3 DASHBOARDS

New **TGS DASHBOARDS** have been added for **MASERATI** vehicles.
Below are a few example images:

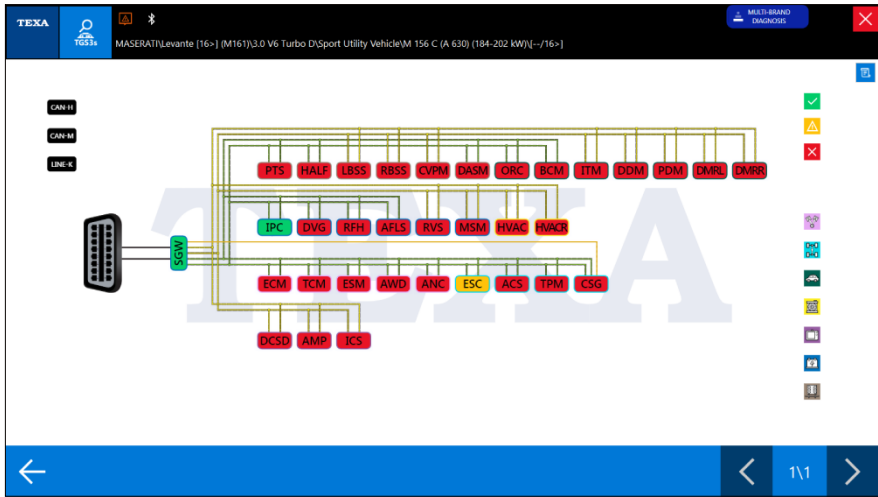

New **PARAMETER DASHBOARDS** have been added for **MASERATI** vehicles.

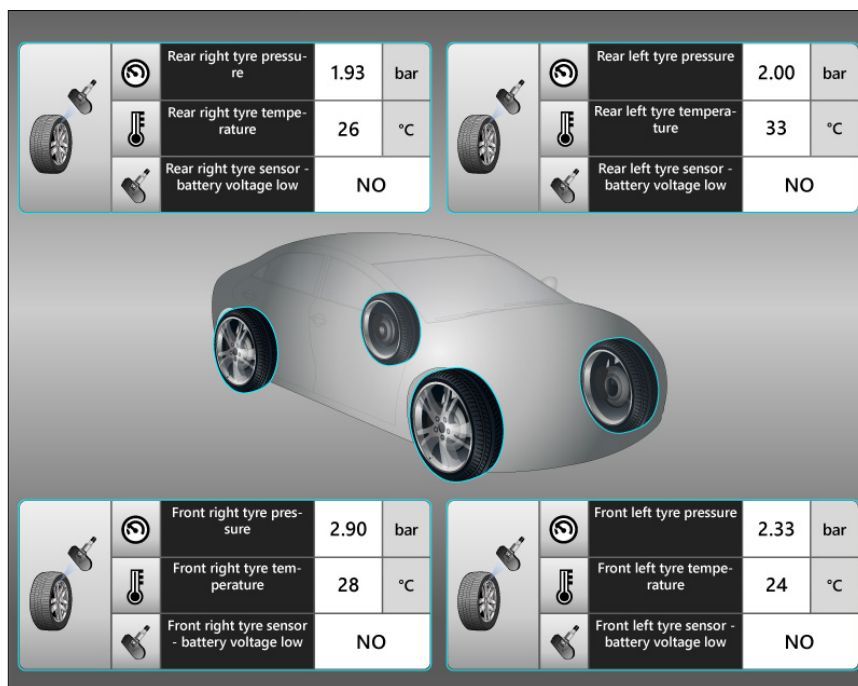

DIAGNOSIS

CAR

ALFA ROMEO

A new diagnostic system has been developed for the model Giulia [16>] (952):

- ABS
- ADAPTIVE CRUISE CONTROL
- AIRBAG
- BODY COMPUTER
- AUTOMATIC TRANSMISSION
- A/C
- FRONT CAMERA
- PETROL INJECTION
- TYRE PRESSURE
- PARK ASSIST
- SGW SECURITY GATEWAY MODULE
- INSTRUMENTATION

A new diagnostic system has been developed for the model Giulietta [10>20] (940):

- PETROL INJECTION



CAR 76.6.1



AUDI

A new diagnosis of the GATEWAY system has been developed for the models:

- A1 [19>] (GBA) Sportback
- A1 [20>] (GBH) Citycarver
- A3 [12>20] (8V1/8VK)
- A3 [12>20] (8VA/8VF) Sportback
- A3 [14>20] (8V7/8VE) Cabrio
- A3 [14>20] (8VS/8VM) Sedan
- S3 [14>20] (8V1/8VK)
- S3 [14>20] (8V7/8VE) Cabrio
- S3 [14>20] (8VA/8VF) Sportback
- S3 [14>20] (8VS/8VM) Sedan
- Q2 [16>] (GAB/GAG)
- Q3 [19>] (F3B)
- Q3 [19>] (F3N) Sportback
- RSQ3 [19>] (F3B)
- TT [14>23] (8S3) Coupé
- TT [14>23] (8S3) S Coupé
- TT [16>23] (8S9) RS Roadster

BMW

A new diagnostic system has been developed for the model 5 [23>] (G60):

- RADAR SENSOR CONTROL UNIT
- DISTANCE CONTROL
- DIESEL INJECTION
- DRIVER ASSISTANCE SUPERVISION SYSTEM
- DRIVER ASSISTANCE SUPERVISION SYSTEM 2

A new diagnosis of the "HYBRID BATTERY" system has been developed for the models:

- iX2 [24>] (U10)

A new diagnosis of the AUTOMATIC TRANSMISSION system has been developed for the models:

- 2 [15>21] (F87)

A new diagnosis of the DISTANCE CONTROL system has been developed for the models:

- 5 [23>] (G60)
- iX2 [24>] (U10)
- X2 [24>] (U10)
- X7 [19>] (G07)
- XM [22>] (G09)



CAR 76.6.1



A new diagnosis of the AIRBAG system has been developed for the models:

- iX2 [24>] (U10)
- X2 [24>] (U10)
- XM [22>] (G09)

A new diagnosis of the EV CONTROL SYSTEM has been developed for the models:

- 2 [21>] (U06) Active Tourer
- iX2 [24>] (U10)

A new diagnosis of the REAR-VIEW CAMERA system has been developed for the models:

- iX2 [24>] (U10)
- X2 [24>] (U10)

A new diagnosis of the PETROL INJECTION system has been developed for the models:

- 2 [21>] (U06) Active Tourer
- 7 [22>] (G70)
- X1 [22>] (U11)
- X2 [24>] (U10)
- X5 [18>] (G05)
- X6 [19>] (G06)
- X7 [19>] (G07)

A new diagnosis of the MULTIFUNCTION CAMERA system has been developed for the models:

- iX2 [24>] (U10)
- X2 [24>] (U10)
- XM [22>] (G09)

A new diagnosis of the PARKING AID CAMERAS system has been developed for the models:

- iX2 [24>] (U10)
- X2 [24>] (U10)
- XM [22>] (G09)

BYD

A new diagnosis of the AIRBAG system has been developed for the models:

- Atto 4 [22>]
- D1 [20>]
- Seal [22>]

A new diagnosis of the FRONT CAMERA system has been developed for the models:

- Atto 4 [22>]
- Dolphin [21>]
- Seal [22>]



CAR 76.6.1



A new diagnosis of the BLIND SPOT MODULE system has been developed for the models:

- Yuan Plus [22>]

CADILLAC

A new diagnostic system has been developed for the model Lyriq [23>]:

- ACTIVE SAFETY CONTROL MODULE 1 - PROCESSOR B
- POWER STEERING

A new diagnostic system has been developed for the model CTS [14>19]:

- PETROL INJECTION

CHEVROLET

A new diagnostic system has been developed for the model Colorado [23>]:

- POWER STEERING

A new diagnostic system has been developed for the model Silverado 1500 [14>19]:

- AUTOMATIC TRANSMISSION

A new diagnostic system has been developed for the model Corvette C8 [20>] Convertible:

- SUNROOF ELECTRONIC CONTROL UNIT
- FRONT AXLE LIFTING

CITROEN

A new diagnostic system has been developed for the model C 3 [22>] (CC21):

- PETROL INJECTION

A new diagnostic system has been developed for the model Berlingo [18>] (K9):

- ADDITIONAL ENGINE HEATING

A new diagnostic system has been developed for the model C 5 Aircross [18>] (C84):

- DC/DC CONVERTER
- PETROL INJECTION

A new diagnosis of the ABS has been developed for the models:

- C 4 [20>] (C41)
- C 4 X [22>] (C43)
- C 5 Aircross [18>] (C84)
- C 5 X [21>] (E43)

A new diagnosis of the AUTOMATIC TRANSMISSION system has been developed for the models:

- C 5 Aircross [18>] (C84)
- C 5 X [21>] (E43)



CAR 76.6.1



A new diagnosis of the DISTANCE CONTROL system has been developed for the models:

- C 5 Aircross [18>] (C84)
- C 4 X [22>] (C43)

A new diagnosis of the A/C system has been developed for the models:

- C 5 Aircross [18>] (C84)
- C 4 X [22>] (C43)

CUPRA

A new diagnostic system has been developed for the model Tavascan [23>]:

- ABS
- AIRBAG
- LANE CHANGE ASSIST
- ELECTRIC MOTOR CONTROL UNIT
- A/C
- DISTANCE CONTROL
- GATEWAY
- BATTERY CONTROL MODULE
- SUSPENSIONS
- MULTIFUNCTION CAMERA
- REAR-VIEW CAMERA
- ELECTRIC DRIVE

DODGE

A new diagnostic system has been developed for the model RAM Rampage [23>]:

- AIRBAG
- DIESEL INJECTION
- FRONT CAMERA
- TELEMATIC ON-BOARD MODULE

A new diagnosis of the ELECTRONIC KEY system has been developed for the models:

- Challenger [08>14] (LC)
- Dakota [04>12] (ND)
- Durango [11>] (WD)
- RAM 3500 [11>] (DD/DF) Cab Chassis
- RAM 4500/5500 [11>] (DP)

DR

A new diagnostic system has been developed for the model DR1.0 [23>]:

- ABS
- AIRBAG
- ELECTRIC MOTOR CONTROL UNIT



CAR 76.6.1



- GATEWAY
- INSTRUMENTATION

A new diagnostic system has been developed for the model DR3.0 [23>]:

- PARK ASSIST
- PETROL INJECTION
- POWER STEERING

A new diagnostic system has been developed for the model DR7.0 [22>]:

- PARK ASSIST

DS

A new diagnostic system has been developed for the model DS 4 [21>] (D41):

- ABS
- AUTOMATIC TRANSMISSION
- PETROL INJECTION
- STEERING ELECTRONICS
- POWER STEERING
- STEERING COLUMN SWITCH UNIT

A new diagnostic system has been developed for the model DS 9 [20>] (X83):

- ABS
- BODY COMPUTER
- PETROL INJECTION
- STEERING ELECTRONICS
- INSTRUMENTATION
- STEERING COLUMN SWITCH UNIT
- ELECTRIC DRIVE

FIAT

A new diagnosis of the "ADDITIONAL ENGINE HEATING" system has been developed for the models:

- Ulysse [22>] (366)
- Doblò [22>] (360)

A new diagnostic system has been developed for the model 600e [23>] (364):

- POWER STEERING

A new diagnostic system has been developed for the model Fiorino Combi [20>] (300):

- ABS
- AIRBAG
- PARK ASSIST
- BODY COMPUTER

- AUTOMATIC TRANSMISSION
- DIESEL INJECTION
- INSTRUMENTATION

A new diagnostic system has been developed for the model Strada II [20>] (281):

- ABS
- AIRBAG
- TYRE PRESSURE
- INSTRUMENTATION

FORD

A new diagnosis of the FRONT INTERFACE MODULE system has been developed for the models:

- Endeavour [23>] (U704)
- Everest [23>] (U704)
- Ranger [22>] (P703)

A new diagnosis of the LEFT SIDE OBSTACLE DETECTION CONTROL UNIT system has been developed for the models:

- Escape IV [19>] (CX482)
- Explorer VI [19>] (U625)
- Kuga III [19>] (CX482)
- Mustang VII [23>] (S650) Cabrio
- Mustang VII [23>] (S650) Coupé
- Tourneo/Transit Courier [24>] (V769)
- Tourneo/Transit Custom [23>] (V710)
- Transit [19>] (V363) Facelift

A new diagnosis of the RIGHT SIDE OBSTACLE DETECTION CONTROL UNIT system has been developed for the models:

- Escape IV [19>] (CX482)
- Explorer VI [19>] (U625)
- Kuga III [19>] (CX482)
- Mustang VII [23>] (S650) Cabrio
- Mustang VII [23>] (S650) Coupé
- Tourneo/Transit Courier [24>] (V769)
- Tourneo/Transit Custom [23>] (V710)
- Transit [19>] (V363) Facelift

A new diagnostic system has been developed for the model Kuga III [19>] (CX482):

- ABS
- ADAPTIVE CRUISE CONTROL
- AIRBAG



CAR 76.6.1



- BODY COMPUTER
- AUTOMATIC TRANSMISSION
- LEFT SIDE OBSTACLE DETECTION CONTROL UNIT
- RIGHT SIDE OBSTACLE DETECTION CONTROL UNIT
- FRONT CAMERA
- GATEWAY
- TYRE PRESSURE
- MULTIFUNCTION CAMERA
- PARKING AID CAMERAS

A new diagnostic system has been developed for the model Ranger [22>] (P703):

- AUTOMATIC TRANSMISSION
- PETROL INJECTION

A new diagnostic system has been developed for the model Tourneo/Transit Courier [24>] (V769):

- AIRBAG
- PETROL INJECTION
- DIESEL INJECTION
- ADAPTIVE CRUISE CONTROL
- MULTIFUNCTION CAMERA
- STEERING COLUMN SWITCH UNIT

A new diagnostic system has been developed for the model Territory [23>] (CX756):

- PETROL INJECTION
- ADAPTIVE CRUISE CONTROL
- FRONT CAMERA

GENESIS

A new diagnosis of the REDUCING AGENT METERING SYSTEM has been developed for the models:

- GV70 [20>] (JK1)
- GV80 [20>] (JX1)

GMC

A new diagnosis of the POWER STEERING system has been developed for the models:

- Canyon [23>]

GREAT WALL

A new diagnosis of the PETROL INJECTION system has been developed for the models:

- Big Dog [20>]
- Haval H6S [22>]
- Jolion [21>]



CAR 76.6.1



A new diagnosis of the FRONT CAMERA system has been developed for the models:

- Big Dog [20>]
- Haval H6 [21>]
- Haval H6S [22>]
- Jolion [21>]

HONDA

A new diagnostic system has been developed for the model CR-V [23>] (RS):

- BLIND SPOT MODULE
- FRONT RADAR
- RADAR
- FRONT LEFT SHORT-RANGE SIDE RADAR SENSOR
- FRONT RIGHT SHORT-RANGE SIDE RADAR SENSOR
- REAR LEFT SHORT-RANGE SIDE RADAR SENSOR
- REAR RIGHT SHORT-RANGE SIDE RADAR SENSOR

A new diagnosis of the AUTOMATIC TRANSMISSION system has been developed for the models:

- Accord IX [13>17] (CT/CR) Coupé

HYUNDAI

A new diagnostic system has been developed for the model Azera [23>] (GN7):

- STEERING ELECTRONICS
- ELECTRONIC KEY
- DRIVER SIDE DOOR

A new diagnostic system has been developed for the model Grandeur [23>] (GN7):

- STEERING ELECTRONICS
- ELECTRONIC KEY
- DRIVER SIDE DOOR

A new diagnostic system has been developed for the model Ioniq 5 [21>] (NE):

- ELECTRONIC KEY

A new diagnosis of the ELECTRONIC KEY system has been developed for the models:

- Kauai [23>] (SX)
- Kona [23>] (SX)
- Santa Fe [23>] (MX5)
- Sonata VIII [23>] (DN8) Facelift

A new diagnosis of the "STEERING ELECTRONICS" system has been developed for the models:

- Kauai [23>] (SX)
- Kona [23>] (SX)



CAR 76.6.1



- Santa Fe [23>] (MX5)
- Sonata VIII [23>] (DN8) Facelift

A new diagnosis of the REDUCING AGENT METERING SYSTEM has been developed for the models:

- Santa Fe [18>23] (TM)
- Staria [22>] (US4)
- Tucson [21>] (NX)

INFINITI

A new diagnostic system has been developed for the model QX50 [19>] (J55):

- PARKING AID CAMERAS

JEEP

A new diagnostic system has been developed for the model Avenger [23>]:

- AIRBAG
- A/C
- DISTANCE CONTROL
- PETROL INJECTION
- POWER STEERING
- MULTIFUNCTION CAMERA

A new diagnostic system has been developed for the model Grand Cherokee [21>] (WL):

- AIRBAG
- PARK ASSIST
- INSTRUMENTATION

A new diagnostic system has been developed for the model Grand Wagoneer [22>] (WS):

- AIRBAG
- PARK ASSIST
- INSTRUMENTATION

A new diagnostic system has been developed for the model Wagoneer [22>] (WS):

- AIRBAG
- PARK ASSIST
- INSTRUMENTATION

KIA

A new diagnostic systems has been developed for the model Sportage [21>] (NQ5):

- REDUCING AGENT METERING SYSTEM
- SERVICE WARNING LIGHT

A new diagnostic system has been developed for the model XCeed [19>] (CD):

- REDUCING AGENT METERING SYSTEM
- AUTOMATIC TRANSMISSION

A new diagnosis of the REDUCING AGENT METERING SYSTEM has been developed for the models:

- Carnival IV [21>] (KA4)
- Ceed [19>] (CD)
- Ceed [19>] (CD) Sportswagon
- ProCeed [19>] (CD)
- Sorento IV [20>] (MQ)

LEXUS

A new diagnostic system has been developed for the model GX (J25) 550 [23>]:

- ABS
- AIRBAG
- AUTOMATIC TRANSMISSION
- BODY COMPUTER
- A/C
- BLIND SPOT MODULE
- GATEWAY
- PETROL INJECTION
- TYRE PRESSURE
- FRONT CORNER RADAR 1
- FRONT CORNER RADAR 2
- RADAR
- PARKING AID CAMERAS
- INSTRUMENTATION

A new diagnostic system has been developed for the model LBX (AY1) [24>]:

- ABS
- AIRBAG
- AUTOMATIC TRANSMISSION
- BODY COMPUTER
- A/C
- BLIND SPOT MODULE
- GATEWAY
- PETROL INJECTION
- TYRE PRESSURE
- FRONT CORNER RADAR 1
- FRONT CORNER RADAR 2
- RADAR
- PARKING AID CAMERAS



CAR 76.6.1



- INSTRUMENTATION

A new diagnostic system has been developed for the model LM (W1) 350h [23>]:

- ABS
- AIRBAG
- AUTOMATIC TRANSMISSION
- BODY COMPUTER
- A/C
- BLIND SPOT MODULE
- GATEWAY
- PETROL INJECTION
- TYRE PRESSURE
- FRONT CORNER RADAR 1
- FRONT CORNER RADAR 2
- RADAR
- PARKING AID CAMERAS
- INSTRUMENTATION

A new diagnostic system has been developed for the model LM (W1) 500h [23>]:

- ABS
- AIRBAG
- AUTOMATIC TRANSMISSION
- BODY COMPUTER
- A/C
- BLIND SPOT MODULE
- GATEWAY
- PETROL INJECTION
- TYRE PRESSURE
- FRONT CORNER RADAR 1
- FRONT CORNER RADAR 2
- RADAR
- PARKING AID CAMERAS
- INSTRUMENTATION

A new diagnostic system has been developed for the model RZ (M1) 300e [23>]:

- ABS
- AIRBAG
- AUTOMATIC TRANSMISSION
- BODY COMPUTER
- A/C
- BLIND SPOT MODULE
- GATEWAY



CAR 76.6.1



- TYRE PRESSURE
- FRONT CORNER RADAR 1
- FRONT CORNER RADAR 2
- RADAR
- PARKING AID CAMERAS
- INSTRUMENTATION

A new diagnostic system has been developed for the model UX (A1) 300e [21>]:

- ABS
- AIRBAG
- BODY COMPUTER
- A/C
- BLIND SPOT MODULE
- GATEWAY
- TYRE PRESSURE
- POWER SOURCE CONTROL

A new diagnosis of the FRONT CAMERA system has been developed for the models:

- GX (J25) 550 [23>]
- LBX (AY1) [24>]
- LM (W1) 350h [23>]
- LM (W1) 500h [23>]
- RZ (M1) 300e [23>]
- UX (A1) 300e [21>]
- UX (A1) 300h [24>]

LINCOLN

A new diagnosis of the LEFT SIDE OBSTACLE DETECTION CONTROL UNIT system has been developed for the models:

- Aviator [19>] (U611)
- Corsair [19>] (CX483)
- Nautilus [24>] (CDX707)

A new diagnosis of the RIGHT SIDE OBSTACLE DETECTION CONTROL UNIT system has been developed for the models:

- Aviator [19>] (U611)
- Corsair [19>] (CX483)
- Nautilus [24>] (CDX707)

A new diagnostic system has been developed for the model Nautilus [24>] (CDX707):

- ABS
- AIRBAG

- ADAPTIVE CRUISE CONTROL
- STEERING COLUMN SWITCH UNIT
- PETROL INJECTION
- MULTIFUNCTION CAMERA
- TYRE PRESSURE
- POWER SOURCE CONTROL

MAZDA

A new diagnostic system has been developed for the model CX-60 [22>] (KH):

- GEAR SELECTOR LEVER
- FRONT LEFT SHORT-RANGE SIDE RADAR SENSOR
- FRONT RIGHT SHORT-RANGE SIDE RADAR SENSOR
- REAR LEFT SHORT-RANGE SIDE RADAR SENSOR
- REAR RIGHT SHORT-RANGE SIDE RADAR SENSOR
- REDUCING AGENT METERING SYSTEM

MERCEDES-BENZ

A new diagnosis of the "HYBRID BATTERY" system has been developed for the models:

- A [18>] (177)
- A [18>] (177) L Sedan
- B [19>] (247)
- CLA [19>] (118)
- CLA [19>] (118) Shooting Brake
- GLA [20>] (247)
- GLB [19>] (247)

A new diagnosis of the AUTOMATIC TRANSMISSION system has been developed for the models:

- A [18>] (177)
- A [18>] (177) L Sedan
- B [19>] (247)
- CLA [19>] (118)
- CLA [19>] (118) Shooting Brake
- GLA [20>] (247)
- GLB [19>] (247)

A new diagnosis of the PETROL INJECTION system has been developed for the models:

- A [18>] (177)
- A [18>] (177) L Sedan
- B [19>] (247)
- CLA [19>] (118)
- CLA [19>] (118) Shooting Brake
- GLA [20>] (247)



CAR 76.6.1



- GLB [19>] (247)

A new diagnosis of the MULTIFUNCTION CAMERA system has been developed for the models:

- Citan Tourer [21>] (420)
- EQT [23>] (420)
- T [22>] (420)

MG

A new diagnosis of the SERVICE WARNING LIGHT system has been developed for the models:

- MG HS [18>] (AS23)
- MG ZS [17>] (ZS11)
- MG ZST [20>] (ZS11)
- MG5 [18>] (AP31)
- MG6 [10>] (IP22)

MINI

A new diagnostic system has been developed for the model Mini (F60) [17>23] Countryman:

- ACTIVE SOUND DESIGN
- SPECIAL EQUIPMENT SYSTEM

A new diagnostic system has been developed for the model Mini (U25) [24>] Countryman:

- RIGHT HEADLIGHT CONTROL UNIT
- LEFT HEADLIGHT CONTROL UNIT
- PETROL INJECTION

MINI

A new diagnostic system has been developed for the model L 200 [24>] (LA/LB/LC/MV):

- AIRBAG
- MULTIFUNCTION CAMERA
- PETROL INJECTION
- GATEWAY
- POWER MODULE
- DISTANCE CONTROL
- CHASSIS MANAGEMENT SYSTEM

A new diagnostic system has been developed for the model Triton [24>] (LA/LB/LC/MV):

- AIRBAG
- MULTIFUNCTION CAMERA
- PETROL INJECTION
- GATEWAY
- POWER MODULE
- DISTANCE CONTROL
- CHASSIS MANAGEMENT SYSTEM



CAR 76.6.1



OPEL

A new diagnostic system has been developed for the model Astra-L [22>]:

- ABS
- BODY COMPUTER
- AUTOMATIC TRANSMISSION
- DC/DC CONVERTER
- DISTANCE CONTROL
- STEERING COLUMN SWITCH UNIT
- PETROL INJECTION
- BATTERY CONTROL MODULE
- MULTIFUNCTION CAMERA
- ELECTRIC DRIVE

A new diagnostic system has been developed for the model Astra-L [22>] Sports Tourer:

- ABS
- BODY COMPUTER
- AUTOMATIC TRANSMISSION
- DC/DC CONVERTER
- DISTANCE CONTROL
- STEERING COLUMN SWITCH UNIT
- PETROL INJECTION
- BATTERY CONTROL MODULE
- MULTIFUNCTION CAMERA
- ELECTRIC DRIVE

A new diagnostic system has been developed for the model Corsa-F [19>]:

- ABS
- AIRBAG
- BODY COMPUTER
- A/C
- DISTANCE CONTROL
- STEERING COLUMN SWITCH UNIT
- PETROL INJECTION
- ADDITIONAL HEATING
- MULTIFUNCTION CAMERA

A new diagnostic system has been developed for the model Mokka [21>]:

- ABS
- AIRBAG
- STEERING COLUMN SWITCH UNIT
- PETROL INJECTION



CAR 76.6.1



PEUGEOT

A new diagnostic system has been developed for the model 208 [19>] (P24):

- ABS
- AIRBAG
- BATTERY ADJUSTMENT
- BODY COMPUTER
- A/C
- DC/DC CONVERTER
- DISTANCE CONTROL
- STEERING COLUMN SWITCH UNIT
- PETROL INJECTION
- ADDITIONAL ENGINE HEATING
- MULTIFUNCTION CAMERA

A new diagnostic system has been developed for the model 208 [19>] (P21):

- ABS
- AIRBAG
- BATTERY ADJUSTMENT
- BODY COMPUTER
- A/C
- DC/DC CONVERTER
- DISTANCE CONTROL
- STEERING COLUMN SWITCH UNIT
- PETROL INJECTION
- ADDITIONAL ENGINE HEATING
- MULTIFUNCTION CAMERA

A new diagnostic system has been developed for the model 308 [21>] (P5):

- ABS
- AUTOMATIC TRANSMISSION
- STEERING COLUMN SWITCH UNIT
- PETROL INJECTION
- POWER STEERING
- ELECTRIC DRIVE

A new diagnostic system has been developed for the model 308 [21>] (P5) Station Wagon:

- ABS
- AUTOMATIC TRANSMISSION
- STEERING COLUMN SWITCH UNIT
- PETROL INJECTION
- POWER STEERING
- ELECTRIC DRIVE





CAR 76.6.1



A new diagnostic system has been developed for the model 408 [22>] (P54):

- ABS
- BATTERY ADJUSTMENT
- AUTOMATIC TRANSMISSION
- DC/DC CONVERTER
- DISTANCE CONTROL
- STEERING COLUMN SWITCH UNIT
- PETROL INJECTION
- POWER STEERING
- MULTIFUNCTION CAMERA
- ELECTRIC DRIVE
- PARKING AID CAMERAS

RENAULT

A new diagnostic system has been developed for the model Austral [22>] (RHN):

- ABS
- AIRBAG
- BODY COMPUTER
- A/C
- FRONT CAMERA
- GATEWAY
- TYRE PRESSURE
- RADAR
- DRIVER ASSISTANCE SUPERVISION SYSTEM
- PARKING AID CAMERAS

A new diagnostic system has been developed for the model Espace VI [23>] (RHN):

- ABS
- AIRBAG
- BODY COMPUTER
- A/C
- FRONT CAMERA
- GATEWAY
- BATTERY CONTROL MODULE
- TYRE PRESSURE
- RADAR
- DRIVER ASSISTANCE SUPERVISION SYSTEM
- PARKING AID CAMERAS

A new diagnostic system has been developed for the model Megane V [22>] (RCB):

- ABS
- AIRBAG



CAR 76.6.1



- BODY COMPUTER
- A/C
- FRONT CAMERA
- GATEWAY
- BATTERY CONTROL MODULE
- TYRE PRESSURE
- RADAR
- DRIVER ASSISTANCE SUPERVISION SYSTEM
- PARKING AID CAMERAS

SEAT

A new diagnosis of the GATEWAY system has been developed for the models:

- Ateca [16>] (KH)
- Ibiza [17>] (6F/KJ1)
- Leon [12>20] (5F1)
- Leon [12>20] (5F5) SC
- Leon [14>20] (5F8) ST
- Leon [14>20] (5F88) X-Perience
- Leon [20>] (KL1)
- Tarraco [19>] (KN)

A new diagnostic system has been developed for the model Arona [17>] (KJ7):

- ABS
- LANE CHANGE ASSIST
- AIRBAG
- AUTOMATIC TRANSMISSION
- A/C
- GATEWAY
- PETROL INJECTION
- PARK ASSIST
- MULTIFUNCTION CAMERA

A new diagnostic system has been developed for the model Leon [20>] (KL1):

- ABS
- LANE CHANGE ASSIST
- AIRBAG
- AUTOMATIC TRANSMISSION
- A/C
- DC/DC CONVERTER
- DISTANCE CONTROL
- PETROL INJECTION
- INJECTION 3/BATTERY 2 CONTROL MODULE

- DIESEL INJECTION
- PARK ASSIST
- MULTIFUNCTION CAMERA
- REAR-VIEW CAMERA

A new diagnostic system has been developed for the model Leon [20>] (KL8) Sportstourer:

- ABS
- LANE CHANGE ASSIST
- AIRBAG
- AUTOMATIC TRANSMISSION
- A/C
- DC/DC CONVERTER
- DISTANCE CONTROL
- PETROL INJECTION
- INJECTION 3/BATTERY 2 CONTROL MODULE
- DIESEL INJECTION
- PARK ASSIST
- MULTIFUNCTION CAMERA
- REAR-VIEW CAMERA

SKODA

A new diagnosis of the GATEWAY system has been developed for the models:

- Enyaq iV [21>] (5AZ)
- Enyaq iV [22>] (5AC) Coupé
- Fabia [21>] (PJ3)
- Kamiq [19>] (NW4)
- Karoq [17>] (NU7)
- Kodiaq [17>] (NS7/NV7)
- Kodiaq [24>] (PS7)
- Kushaq [21>] (PA1)
- Octavia [13>19] (5E3)
- Octavia [13>19] (5E5) Kombi
- Scala [19>] (NW1)
- Slavia [22>] (PB2)
- Superb B9 [24>] (NZ3)

A new diagnostic system has been developed for the model Enyaq iV [21>] (5AZ):

- ABS
- LANE CHANGE ASSIST
- AIRBAG
- AUTOMATIC TRANSMISSION
- A/C



CAR 76.6.1



- ELECTRIC MOTOR CONTROL UNIT
- 12V VOLTAGE CONVERTER
- DISTANCE CONTROL
- BATTERY CHARGER CONTROL MODULE
- PARK ASSIST
- POWER STEERING
- SUSPENSIONS
- ELECTRIC DRIVE
- ELECTRIC DRIVE 2
- MULTIFUNCTION CAMERA
- REAR-VIEW CAMERA

A new diagnostic system has been developed for the model Enyaq iV [22>] (5AC) Coupé:

- ABS
- LANE CHANGE ASSIST
- AIRBAG
- AUTOMATIC TRANSMISSION
- A/C
- ELECTRIC MOTOR CONTROL UNIT
- 12V VOLTAGE CONVERTER
- DISTANCE CONTROL
- BATTERY CHARGER CONTROL MODULE
- PARK ASSIST
- POWER STEERING
- SUSPENSIONS
- ELECTRIC DRIVE
- ELECTRIC DRIVE 2
- MULTIFUNCTION CAMERA
- REAR-VIEW CAMERA

A new diagnostic system has been developed for the model Fabia [21>] (PJ3):

- ABS
- LANE CHANGE ASSIST
- AIRBAG
- AUTOMATIC TRANSMISSION
- A/C
- DISTANCE CONTROL
- GATEWAY
- PETROL INJECTION
- PARK ASSIST
- POWER STEERING
- SUSPENSIONS



CAR 76.6.1



- MULTIFUNCTION CAMERA
- REAR-VIEW CAMERA

A new diagnostic system has been developed for the model Kamiq [19>] (NW4):

- ABS
- LANE CHANGE ASSIST
- AIRBAG
- AUTOMATIC TRANSMISSION
- A/C
- DISTANCE CONTROL
- PETROL INJECTION
- PARK ASSIST
- POWER STEERING
- SUSPENSIONS
- MULTIFUNCTION CAMERA
- REAR-VIEW CAMERA

A new diagnostic system has been developed for the model Kodiaq [24>] (PS7):

- ELECTRIC DRIVE
- DC/DC CONVERTER
- AUTOMATIC TRANSMISSION
- A/C
- DISTANCE CONTROL
- GATEWAY
- PETROL INJECTION
- DIESEL INJECTION
- SHORT-RANGE RADAR SENSOR 1
- SHORT-RANGE RADAR SENSOR 2
- SHORT-RANGE RADAR SENSOR 3
- SHORT-RANGE RADAR SENSOR 4
- POWER STEERING
- SUSPENSIONS
- MULTIFUNCTION CAMERA
- REAR-VIEW CAMERA

A new diagnostic system has been developed for the model Superb B9 [24>] (NZ3):

- DC/DC CONVERTER
- A/C
- DISTANCE CONTROL
- PETROL INJECTION
- DIESEL INJECTION
- SHORT-RANGE RADAR SENSOR 1

- SHORT-RANGE RADAR SENSOR 2
- SHORT-RANGE RADAR SENSOR 3
- SHORT-RANGE RADAR SENSOR 4
- POWER STEERING
- SUSPENSIONS
- REAR-VIEW CAMERA

SPORTEQUIPE

A new diagnostic system has been developed for the model S5 [23>]:

- PETROL INJECTION
- PARK ASSIST
- POWER STEERING

A new diagnostic system has been developed for the model S6 [23>]:

- PETROL INJECTION
- PARK ASSIST
- POWER STEERING

A new diagnostic system has been developed for the model S7 [23>]:

- PETROL INJECTION
- PARK ASSIST
- POWER STEERING

SUZUKI

A new diagnosis of the FRONT CAMERA system has been developed for the models:

- Jimny [18>] (A6G)
- Spacia [17>]
- Wagon R [17>]

TOYOTA

A new diagnostic system has been developed for the model Century [23>] (G70):

- ABS
- AIRBAG
- HYBRID BATTERY
- BODY COMPUTER
- BLIND SPOT MODULE
- A/C
- FRONT CAMERA
- GATEWAY
- PETROL INJECTION
- BATTERY CHARGER CONTROL MODULE
- TYRE PRESSURE
- PARK ASSIST



CAR 76.6.1



- POWER SOURCE CONTROL
- FRONT CORNER RADAR 1
- FRONT CORNER RADAR 2
- RADAR
- POWER STEERING
- PARKING AID CAMERAS

A new diagnostic system has been developed for the model Land Cruiser [23>] (J250) Prado:

- ABS
- ADAPTIVE CRUISE CONTROL
- AIRBAG
- BODY COMPUTER
- BLIND SPOT MODULE
- AUTOMATIC TRANSMISSION
- A/C
- ELECTRIC MOTOR CONTROL UNIT
- FRONT CAMERA
- GATEWAY
- PETROL INJECTION
- DIESEL INJECTION
- TYRE PRESSURE
- PARK ASSIST
- POWER SOURCE CONTROL
- FRONT CORNER RADAR 1
- FRONT CORNER RADAR 2
- RADAR
- POWER STEERING
- PARKING AID CAMERAS

A new diagnostic system has been developed for the model Prius [23>] (W60):

- ABS
- HYBRID BATTERY
- AIRBAG
- BODY COMPUTER
- BLIND SPOT MODULE
- A/C
- ELECTRIC MOTOR CONTROL UNIT
- FRONT CAMERA
- GATEWAY
- HYBRID SYSTEM
- BATTERY CHARGER CONTROL MODULE
- PETROL INJECTION



CAR 76.6.1



- TYRE PRESSURE
- PARK ASSIST
- POWER SOURCE CONTROL
- FRONT CORNER RADAR 1
- FRONT CORNER RADAR 2
- RADAR
- POWER STEERING
- PARKING AID CAMERAS

A new diagnostic system has been developed for the model Tacoma [23>] (N4):

- ABS
- AIRBAG
- BODY COMPUTER
- BLIND SPOT MODULE
- A/C
- AUTOMATIC TRANSMISSION
- FRONT CAMERA
- GATEWAY
- PETROL INJECTION
- TYRE PRESSURE
- PARK ASSIST
- POWER SOURCE CONTROL
- RADAR
- POWER STEERING
- PARKING AID CAMERAS

A new diagnostic system has been developed for the model Yaris [20>] (P21):

- FRONT CAMERA
- IMMOBILISER
- NAVIGATOR

VOLKSWAGEN

A new diagnosis of the GATEWAY system has been developed for the models:

- Arteon [17>] (3H7/3H8)
- Arteon [20>] (3H9) Shooting Brake
- Atlas [17>] (CA1/CM)
- Golf VII [12>20] (5G1/BC1)
- Golf VII [14>20] (BA5) Variant
- Golf VII [15>20] (AM1) Sportsvan
- Golf VIII [20>] (CD1)
- Golf VIII [20>] (CG5) Variant
- ID.4 [21>] (E21)



CAR 76.6.1



- ID.5 [22>] (E39)
- ID.7 [23>] (ED2)
- Nivus [20>] (CH1)
- Passat B9 [24>] (CJ5)
- Polo [18>] (BZ1)
- Taigo [21>] (CS1)
- Taigun [21>] (CW1)
- Taos [21>] (CL1)
- Tiguan [24>] (CT1)
- T-Roc [17>] (A11/D11)
- T-Roc [20>] (AC7/AC8) Cabriolet

A new diagnostic system has been developed for the model Arteon [17>] (3H7/3H8):

- ABS
- LANE CHANGE ASSISTANT
- AIRBAG
- A/C
- AUTOMATIC TRANSMISSION
- MULTIFUNCTION CAMERA
- PETROL INJECTION
- TYRE PRESSURE
- PARK ASSIST
- POWER STEERING
- INFORMATION ELECTRONIC SYSTEM 1
- REAR-VIEW CAMERA

A new diagnostic system has been developed for the model Arteon [20>] (3H9) Shooting Brake:

- ABS
- FOUR-WHEEL DRIVE
- LANE CHANGE ASSISTANT
- AIRBAG
- A/C
- AUTOMATIC TRANSMISSION
- LEFT HEADLIGHT CONTROL UNIT
- RIGHT HEADLIGHT CONTROL UNIT
- DISTANCE CONTROL
- MULTIFUNCTION CAMERA
- PETROL INJECTION
- TYRE PRESSURE
- PARK ASSIST
- POWER STEERING
- INFORMATION ELECTRONIC SYSTEM 1



CAR 76.6.1



- REAR-VIEW CAMERA

A new diagnostic system has been developed for the model Golf VIII [20>] (CD1):

- ABS
- LANE CHANGE ASSISTANT
- AIRBAG
- A/C
- AUTOMATIC TRANSMISSION
- DC/DC CONVERTER
- LEFT HEADLIGHT CONTROL UNIT
- RIGHT HEADLIGHT CONTROL UNIT
- DISTANCE CONTROL
- MULTIFUNCTION CAMERA
- PETROL INJECTION
- INJECTION 3/BATTERY 2 CONTROL MODULE
- START/CHARGING CONTROL MODULE
- PARK ASSIST
- POWER STEERING
- REAR-VIEW CAMERA

A new diagnostic system has been developed for the model Golf VIII [20>] (CG5) Variant:

- ABS
- FOUR-WHEEL DRIVE
- LANE CHANGE ASSISTANT
- AIRBAG
- A/C
- AUTOMATIC TRANSMISSION
- DC/DC CONVERTER
- LEFT HEADLIGHT CONTROL UNIT
- RIGHT HEADLIGHT CONTROL UNIT
- DISTANCE CONTROL
- MULTIFUNCTION CAMERA
- PETROL INJECTION
- INJECTION 3/BATTERY 2 CONTROL MODULE
- START/CHARGING CONTROL MODULE
- PARK ASSIST
- POWER STEERING
- REAR-VIEW CAMERA

A new diagnostic system has been developed for the model ID.7 [23>] (ED2):

- ABS
- LANE CHANGE ASSISTANT



CAR 76.6.1



- AIRBAG
- A/C
- DC/DC CONVERTER
- LEFT HEADLIGHT CONTROL UNIT
- RIGHT HEADLIGHT CONTROL UNIT
- DISTANCE CONTROL
- MULTIFUNCTION CAMERA
- BATTERY CONTROL MODULE
- ELECTRIC DRIVE
- ELECTRIC DRIVE 2
- PARK ASSIST
- POWER STEERING
- REAR-VIEW CAMERA

A new diagnostic system has been developed for the model Passat B9 [24>] (CJ5):

- FOUR-WHEEL DRIVE
- LANE CHANGE ASSISTANT
- A/C
- DC/DC CONVERTER
- LEFT HEADLIGHT CONTROL UNIT
- RIGHT HEADLIGHT CONTROL UNIT
- DISTANCE CONTROL
- MULTIFUNCTION CAMERA
- PETROL INJECTION
- DIESEL INJECTION
- SHORT-RANGE RADAR SENSOR 1
- SHORT-RANGE RADAR SENSOR 2
- SHORT-RANGE RADAR SENSOR 3
- SHORT-RANGE RADAR SENSOR 4
- ELECTRIC DRIVE
- POWER STEERING
- REAR-VIEW CAMERA

A new diagnostic system has been developed for the model Tiguan [24>] (CT1):

- FOUR-WHEEL DRIVE
- LANE CHANGE ASSISTANT
- A/C
- DC/DC CONVERTER
- LEFT HEADLIGHT CONTROL UNIT
- RIGHT HEADLIGHT CONTROL UNIT
- DISTANCE CONTROL

- PETROL INJECTION
- DIESEL INJECTION
- SHORT-RANGE RADAR SENSOR 1
- SHORT-RANGE RADAR SENSOR 2
- SHORT-RANGE RADAR SENSOR 3
- SHORT-RANGE RADAR SENSOR 4
- ELECTRIC DRIVE
- POWER STEERING
- MULTIFUNCTION CAMERA
- REAR-VIEW CAMERA

SUPERCAR

FERRARI

A new diagnosis of the POWER STEERING system has been developed for the models:

- 812 Superfast Competizione [21>] (F152MVS)
- Portofino M [20>] (F164FL)
- Roma [20>] (F169)

MASERATI

A new diagnostic system has been developed for the model GranTurismo [23>] (M189):

- ABS
- SGW SECURITY GATEWAY MODULE
- PETROL INJECTION
- FOUR-WHEEL DRIVE
- FORWARD AND REVERSE SENSING ADAS SYSTEM
- INSTRUMENTATION

A new diagnostic system has been developed for the model Grecale [22>] (M182):

- ABS
- SGW SECURITY GATEWAY MODULE
- FOUR-WHEEL DRIVE
- FORWARD AND REVERSE SENSING ADAS SYSTEM
- INSTRUMENTATION

A new diagnostic system has been developed for the model MC20 [20>] (M240):

- SGW SECURITY GATEWAY MODULE
- FOUR-WHEEL DRIVE
- INSTRUMENTATION



CAR 76.6.1



PORSCHE

A new diagnostic system has been developed for the model 911 [19>] (992):

- LANE CHANGE ASSIST
- LANE CHANGE ASSIST 2

A new diagnosis of the "INSTRUMENTATION" system has been developed for the models:

- Cayenne [18>] (9YA)

ROLLS-ROYCE

A new diagnostic system has been developed for the model Ghost [09>20] (RR4):

- ABS
- AIRBAG
- DISTANCE CONTROL
- FRONT RIGHT DAMPER ELECTRONICS
- FRONT LEFT DAMPER ELECTRONICS
- REAR RIGHT DAMPER ELECTRONICS
- REAR LEFT DAMPER ELECTRONICS

A new diagnostic system has been developed for the model Ghost [21>] (RR21):

- ABS
- AIRBAG
- PARK ASSIST
- AUTOMATIC TRANSMISSION
- BODY COMPUTER
- DISTANCE CONTROL
- GATEWAY
- MULTIFUNCTION CAMERA
- PARK ASSIST CAMERA

A new diagnosis of the AUTOMATIC TRANSMISSION system has been developed for the models:

- Phantom [07>16] (RR2) Drophead
- Phantom [08>16] (RR3) Coupé

NOTICE FOR CUSTOMERS WHO OWN A Windows PC

Dear Customers, to make the most of all the functions in the TEXA IDC5 diagnostic software, you need to update your Personal Computers to the latest version of the operating system Windows 10 or Windows 11.

OTHER NOTICES

Please note that the software updates are not available for unsupported tools.

For more information, please contact your trusted TEXA dealer.

Please note that this document is confidential. Total or partial copying without authorisation by TEXA S.p.A. is forbidden. Data, descriptions and illustrations may vary with respect to those shown here. TEXA S.p.A. reserves the right to make changes of any kind to its products, without prior notice.